

Infrared stimulated photoluminescence dating of sediments

G. Hütt† and J. Jaek §

†Institute of Geology, Estonia pst. 7, Tallinn 200101, USSR

§Tartu State University, Tähe 4, Tartu 202400, USSR

Following the original idea by Huntley et al (1985) to use the photoluminescence (PL) of quartz for dating, and the subsequent investigations by Smith et al (1986), we were encouraged to study the physical basis of the phenomenon. The first stimulation spectra for alkali feldspars were reported at Tallinn in April, 1987 at the Conference "Isotope methods for Baltic regional geological problems", and then in Cambridge (Hütt et al, 1988). It was shown that within a spectral region from green to the infrared, the alkali feldspar PL stimulation is connected with quite stable traps and may be used for dating. On the basis of (preliminary) experiments, a PL energy diagram was proposed with a corresponding mechanism, which explained the unexpected stability of "infrared" traps. As a result of these studies, infrared stimulation of alkali feldspars was proposed for optical dating. This permits much simplified equipment compared with that required when using green stimulation, and solves problems of interference of the stimulating light with the measured luminescence. The first "infrared" dates obtained seem to be promising.

Physical basis

The final stimulation spectra of natural alkali feldspar was obtained (fig. 1) using a pulsed excimer dye laser as a light source. This is an improvement over the previous Xe lamp system because it avoids the cutting effects of filters, and it confirms that the signal is relatively weak when using green stimulation. (see fig. 1). More detailed experiments were performed with the aim of calculating the energy parameters of the corresponding traps. As was confirmed in our previous paper (Hütt et al, 1988), the alkali feldspar PL response is a result of a complicated thermo-optical mechanism; green light transports electrons from the ground state directly to the conduction band, but infrared light ensures that electrons are only transported to excited states where additional energy (thermal activation) is needed for transition to the conduction band. The last process is exponentially dependent on temperature:

$$I = I_0 \exp \frac{E_T^*}{kT} \quad (1)$$

where, I and I_0 are the PL intensities after infrared stimulation at a temperature of T and at room temperature, respectively; k is the Boltzmann constant, and E_T^* is the thermal activation energy.

The slope of $\ln I/I_0$ vs $1/T$ yields $E_T^* = 0.2 \pm 0.1$ eV which is the thermal activation energy for electrons from excited states to the conduction band (this value was previously measured indirectly as 0.8 eV). Within error limits this value was the same for infrared stimulation with both $E_{\lambda 1} = 1.33$ eV and $E_{\lambda 2} = 1.43$ eV.

The thermo-optical bleaching (TOB) curve (after sample preheating to 250 °C) can give an estimate of the ground state thermal activation energy (fig. 2, curve 1) using the method described by Luschik (1955). Since the order of the kinetic process has not been reliably established, the results for both first and second order are considered.

$$E_T = \frac{kT_m^2}{\delta_K \ln 2} = 1.55 \pm 0.2 \text{ eV (I order)} \quad (2)$$

$$E_T = \frac{2kT_m^2}{\delta_K \ln 2} = 2.15 \pm 0.2 \text{ eV (II order)} \quad (3)$$

where, T_m is the temperature at which the PL is at half the intensity of the initial value, and where δ_K is the temperature interval over which this fall has occurred.

On the basis of more precise experiments than reported in Hütt et al (1988), a new energy diagram is suggested (see fig. 3). The existence of an infrared stimulated PL signal even at room temperature is understandable considering the rather small activation energy needed for electrons to be transported from the excited state to the conduction band (only 0.2eV). There are several possible explanations for the relatively easy PL signal bleachability by natural light (compared with TL). Huntley et al (1985) suggested optical selection of particularly light sensitive grains; existence of especially light sensitive traps may be an alternative explanation. On the basis of the experiments discussed above (see fig. 2) it is possible to suggest that the same trap is responsible for both the TL and PL observed. There is good correlation between the high temperature maximum of the TL and the temperature at which the PL has fallen to half of its maximum (~310 °C). Furthermore, assuming first order kinetics, the activation energy of the corresponding TL trap was estimated by Strickertsson (1985) to be 1.62 ± 0.05 eV, and independently by us

Figure 1. Alkali feldspars PL-response stimulation spectra.
I = intensity of PL response in arbitrary units;
E = energy of stimulating light (eV).

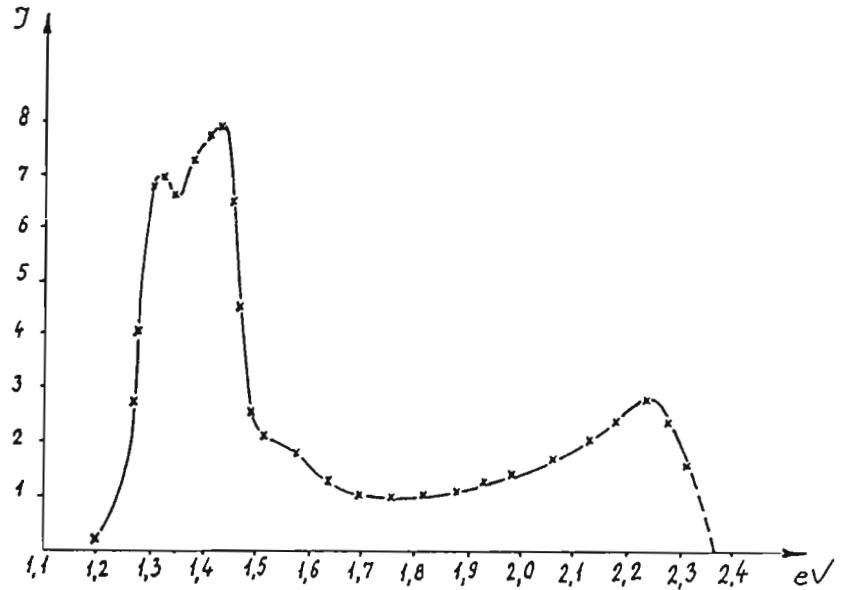

Figure 2. Thermo-optical bleaching curve (1) and TL glow curve (2). *I* = intensity of PL response for stimulation with light $E_\lambda = 1.43\text{eV}$ (1.33eV) (1) or TL-intensity (2). For (1) the sample was preheated to 250 °C.

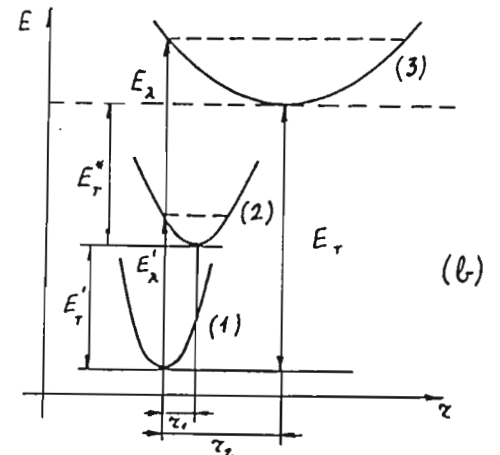
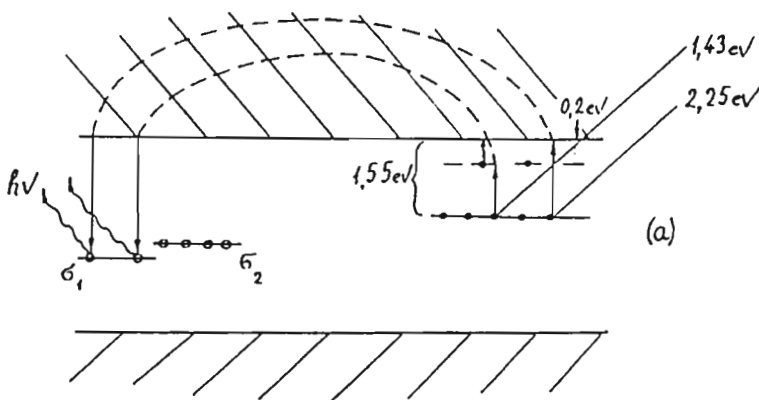
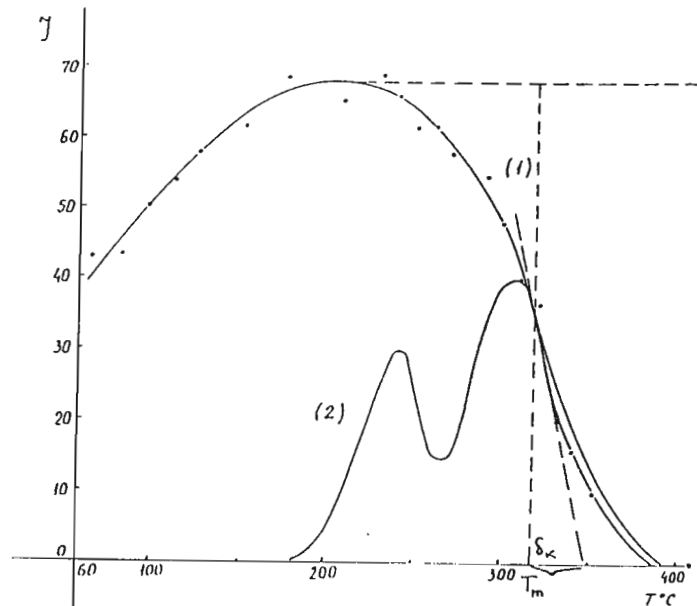

Figure 3. Energy diagram of PL-processes (a) and the same process in potential configuration coordinates (b): 1 = ground state, 2 = excited state, 3 = conduction band
 $E_T = 1.55(2.15)\text{ eV}$ $E_\lambda = 2.25\text{eV}$; $E_T^* = 0.2\text{eV}$; $E_\lambda' = 1.43(1.33)\text{ eV}$; $E_T' = 1.35(1.95)\text{ eV}$.

to be 1.7 ± 0.05 eV. This is in good agreement with the ground state activation energy of 1.55 ± 0.2 eV from TOB analysis. The differences in light sensitivity of the PL and TL signals may be connected with the distribution of charge to the recombination centres involved in TL and PL processes. Obviously only the quick component of TL-signal bleaching (Wintle and Huntley 1982; Hütt, 1988) is seen as PL. We propose that this is a result of electron recombination at centres with greater effective cross section (σ_1 in fig. 3) than those responsible for much of the TL emission (σ_2). To check this hypothesis it will be necessary to study the spectral composition of the PL response. The experimental results can be used to give an indication of the order of kinetics of the PL process. The coefficient $a = E_{\lambda}/E_T$ is not constant - the value is characteristic of particular electron transitions, but in any case it has to be greater than 1. If the kinetics of the process are second order then the "infrared" electron transition from the ground state to the excited state (λ_1) gives:

$$a = \frac{E_{\lambda_1}}{E_T} = \frac{1.33}{1.95} \text{ eV} < 1,$$

which is clearly incorrect (same for λ_2).

E_T is the energy of activation from the ground state to the excited state, calculated by $E_T = E_T - E_T^* = 2.15 - 0.2 = 1.95$ eV (see fig.3). Hence we suspect that the PL is closer to a first order kinetic process.

Infrared PL dating

Using the theory discussed above as a basis, new equipment was developed which is very small and simple in operation. As a source of stimulation, an infrared laser (860 nm; 40 mW) is used which gives a light intensity at the sample of ~ 7 mW cm⁻². The laser can work in either continuous or pulse mode. The time of the pulse can be changed automatically (we use a 3 sec. pulse). A special chamber is used with a mirror to maximize the PL signal collection. The PL response (~ 400 nm) is detected by a photon counting system in parallel with a multichannel analyser. We have detected only alkali feldspar PL signals - infrared stimulation in this region was not effective for quartz. To investigate the PL signal sensitivity to natural light, bleaching studies were conducted by exposing bulk samples of alkali feldspars to sunlight (fig. 4). We have to be very quick and careful during sampling; more than 50% of the PL signal may be lost during 5 minutes of sun exposure. Our preliminary results from dating samples with different genesis from different localities (~ 70 samples) were successful with dunes and marine sediments. Lake sediments were almost as successful, but the results from fluvio-glacial samples were problematic. Following from our paleodose laboratory reconstruction model (ibid, Hütt and Poljacov) we tentatively suggest that "infrared" PL dating is

applicable to samples within the age range $\sim 10^3$ to $3 \cdot 10^5$ a. Examples of preliminary dating results are given in fig. 5. We used the additive dose method with exponential fitting. For TL and PL dating, the same samples were used. "Zero" reconstruction for TL was performed using the R- Γ procedure and total bleach methods. ESR dates on shell were obtained by Molodkov (Tallinn). The good correlation between the three paleodosimetric dating methods testifies to the accuracy of the results.

Conclusions

1. A more precise energy diagram describing the observed PL from alkali feldspars is proposed.
2. It is suggested that the TL and PL dating traps are connected with the same type of crystal defects. The particularly high light sensitivity in the case of PL is most likely due to recombination at a different centre.
3. The infrared dating of some marine sediments has given results which are in good agreement with TL and ESR dating.
4. The expected lower and upper age limits for the infrared PL dating method are 10^3 and 10^5 a respectively.

References

- Huntley, D.J., Godfrey-Smith, D.I. and Thewalt, M.L.W. (1985) Optical dating of sediments, *Nature*, London, 313, 105-107.
- Hütt, G., Jaek, I. and Tchonka, J. (1988) Optical dating: K-feldspars optical response stimulation spectra, *Quat. Sci. Rev.*, 7(3-4), 381- 385.
- Hütt, G. (1988) Methodological problems of TL-dating of Holocene sand dunes and marine sediments, *Proc. of the Acad. of Science. of ESSR, Geology*, 37 (4), 153-163 (in Russian).
- Luschik, Ch. (1955) Studies of trap centers in alkali halides, *Proc. of the Institute of Physics and Astronomy, Acad. of Science. ESSR, Tartu*, 3, 229 (in Russian).
- Smith, B.W., Aitken, M.J., Rhodes, E.J., Robinson, P.D. and Geldard, D.M. (1986) Optical Dating: methodological aspects. *Radiat. Protect. Dosim.*, 17, 229-233.
- Strickertsson, K. (1985) The thermoluminescence of potassium feldspars - glowcurve characteristics and initial rise measurements, *Nucl. Tracks and Radn. Meas.*, 10(4-6), 613-617.
- Wintle, A.G., and Huntley, D.J. (1982) Thermoluminescence dating of sediments. *Quat. Sci. Reviews.*, 1, 31-51.

Reviewed by B.W. Smith and I.K. Bailiff

This paper was first presented at the Oxford Workshop *Long and short range limits in luminescence dating* in April 1989. In view of the desirability to have wider circulation of the research results contained in this paper, we invited the authors to submit their paper for publication in *Ancient TL*.

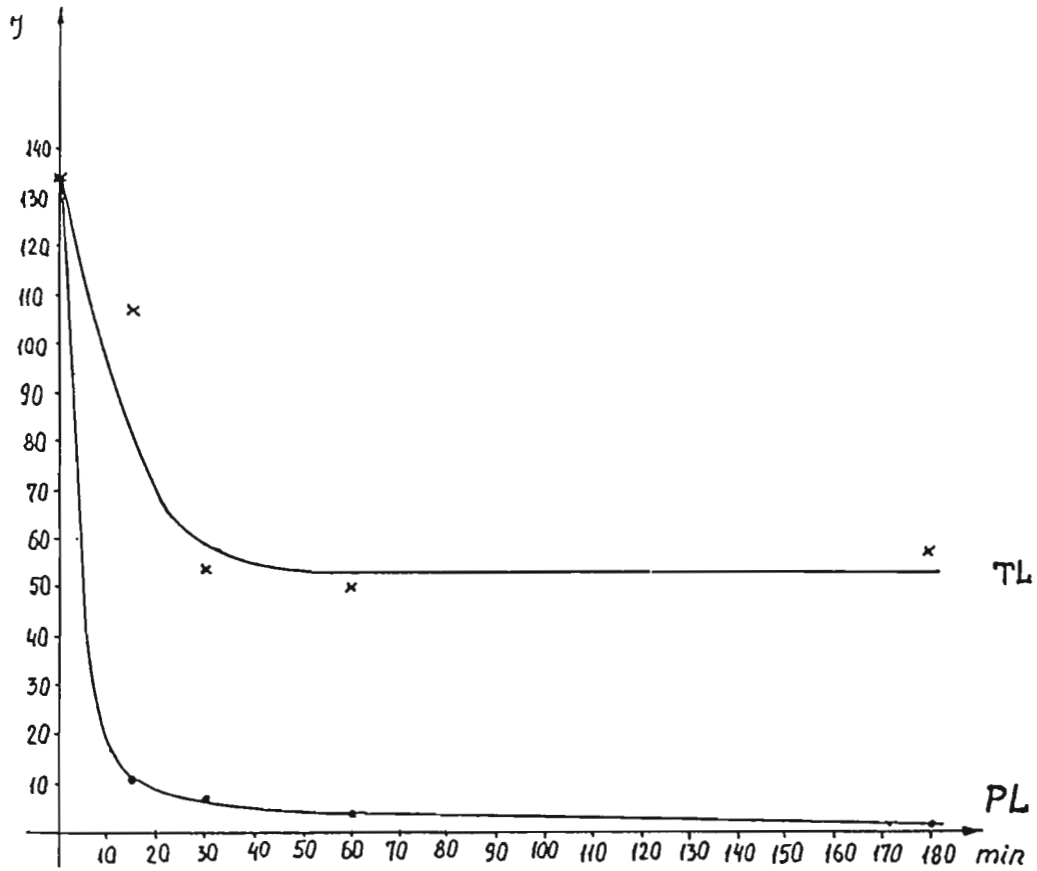

Figure 4. Bleaching of signals by sunlight for a bulk sample (following alkali feldspar extraction).

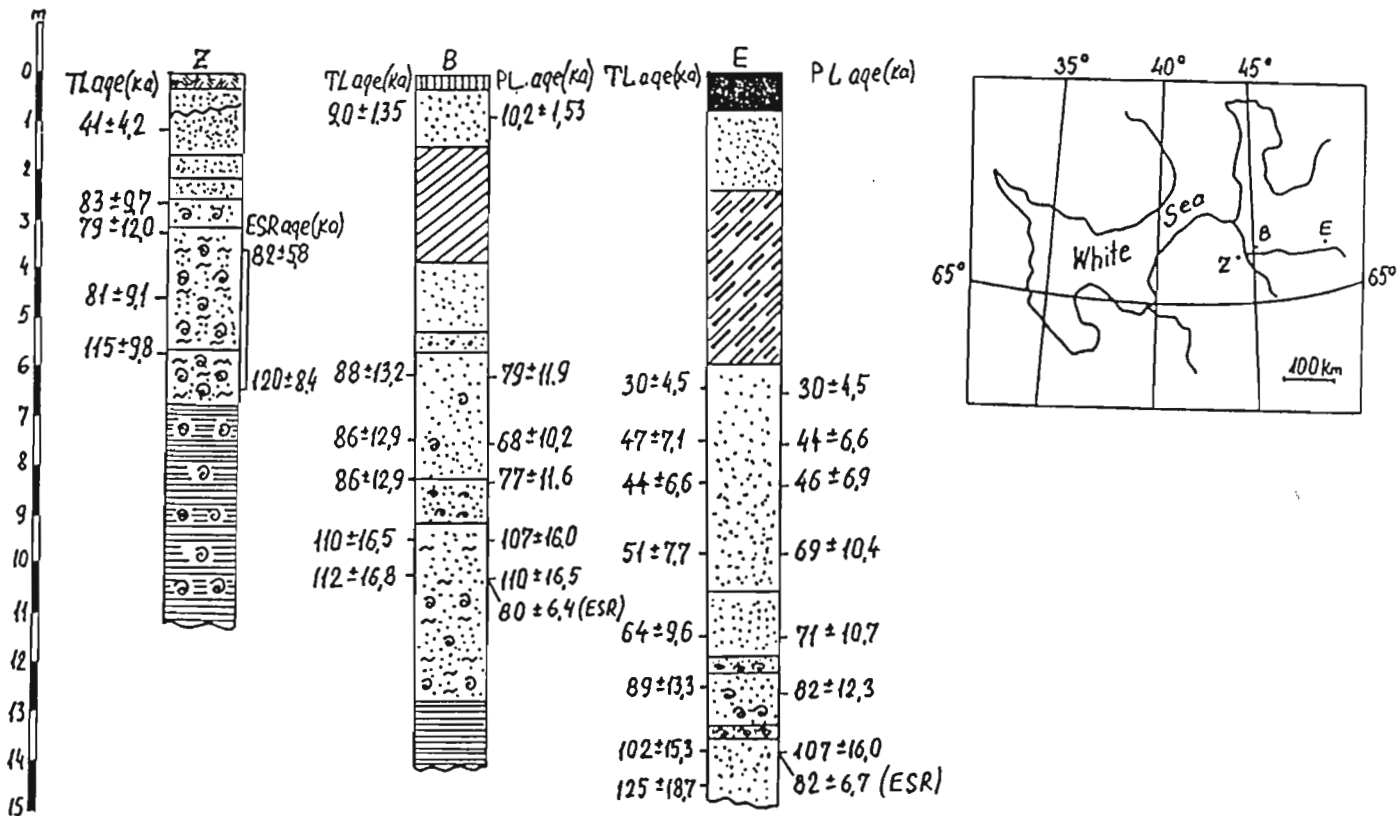

Figure 5. Palaeodosimetrical dating results for marine sediments.